

 **PEAK<sup>®</sup> Aluminum Railing**

# 42" H System

## 2023 Florida Building Code Report

**⚠ WARNING** No representation or warranty is given that your particular application of these products complies with relevant building codes or that the fasteners provided or used are appropriate for your application. Consult with professionals and local building officials before beginning work: (i) to ensure compliance with relevant building codes for your application and for your proposed use of fasteners; (ii) to ensure the integrity of the structural components in connection with which these products are to be used; (iii) to identify appropriate safety gear that is to be used during installation such as a safety harness when working above ground; (iv) to ensure that the work area is free from utilities, services and hazards; and (v) to clarify any instructions or warnings that may not be clear. Work in a safe manner wearing protective gear such as gloves, eyewear, headwear, footwear and clothing. When using tools comply with operation manuals and instructions. Metal and glass may have sharp edges and could fragment or splinter during or as a result of handling or cutting. Do not use these products in connection with any substance that is or may be harmful or corrosive to the products. Inspect and maintain these products and the structural components that they are used in connection with on a regular basis, using professionals when appropriate.

## Peak™ Aluminum 42” Railing System

### Engineering Review for Compliance with 2023 Florida Building Code

Peak Products USA Corporation  
[www.peakproducts.com](http://www.peakproducts.com)

Submitted April 23, 2024 by  
RDH Building Science Inc.  
4333 Still Creek Drive #400  
Burnaby BC V5C 6S6

# Contents

<b>1</b>	<b>Overview</b>	<b>1</b>
1.1	Infill Elements	1
1.2	Rail Elements	1
1.3	Connectors	2
<b>2</b>	<b>Infill Elements</b>	<b>2</b>
2.1	Aluminum Infill Elements	2
2.2	Glass Infill Elements	2
<b>3</b>	<b>Rail Elements</b>	<b>3</b>
3.1	General Rail Elements	3
<b>4</b>	<b>Connectors</b>	<b>3</b>
4.1	General Connectors	3
<b>5</b>	<b>Results</b>	<b>4</b>
<b>6</b>	<b>Conclusion</b>	<b>5</b>

## Appendices

**Appendix A List of Components**

**Appendix B Assembly Drawings**

# 1 Overview

The Peak™ Aluminum Railing System is intended to act as a guard or barrier to protect the public from a fall. The objectives were to complete a structural review of the structural components based in accordance with applicable material standards and the 2023 Florida Building Code (FBC).

The following specified loads apply:

- Concentrated load of 200 pounds applied in any direction at any point along the top rail.
- Uniformly distributed load of 50 pounds per linear foot applied in any direction along the top rail.
- Horizontally applied normal load of 50 pounds on an area equal to 1 square foot.
- Uniform wind load per the limits shown in Appendix B Assembly Drawings.

Material resistances will be determined in accordance with the respective design codes AA-ADM-1 Aluminum Design Manual 2020, and ASTM E-1300-16 Standard Practice for Determining Load Resistance of Glass in Buildings.

In this report, the following structural components were reviewed:

## 1.1 Infill Elements

- Aluminum pickets 16 mm (5/8") wide - Dwg. Title "Aluminum Railing - Railing Assembly with Pickets"
- Aluminum pickets 38 mm (1½") wide - Dwg. Title "Aluminum Railing - Railing Assembly with Wide Pickets"
- Glass panels up to 1676 mm (66") wide - Dwg. Title "Aluminum Railing - Railing Assembly with Glass Panel"
- Glass panels 152 mm (6") wide - Dwg. Title "Aluminum Railing - Railing Assembly with 6" Glass Panel"

## 1.2 Rail Elements

- Post - Dwg. Title "Posts"
- Hand rail - See Report Assembly Drawings
- Base rail - See Report Assembly Drawings
- Stair hand rail - See Report Assembly Drawings

## 1.3 Connectors

- Universal connector – Dwg. Title “Brackets and Connectors”
- Wall mount bracket – Dwg. Title “Brackets and Connectors”
- Mid/Stair/End fascia mount bracket – Dwg. Title “Fascia Mount Brackets”
- Corner fascia mount bracket – Dwg. Title “Fascia Mount Brackets”
- Stair hand and base rail bracket – Dwg. Title “Aluminum Railing – Stair Railing Assembly with Pickets” and “Aluminum Railing – Stair Railing Assembly with Wide Pickets”

The complete list of all components (including non-structural components) for the system is included in Appendix A.

## 2 Infill Elements

The primary infill elements include the following:

- Aluminum pickets 16 mm (5/8”) wide
- Aluminum pickets 38 mm (1½”) wide
- Glass panels up to 1676 mm (66”) wide
- Glass panels 152 mm (6”) wide

This review is based on information and drawings provided by Peak™ Products USA Corporation (Peak) for the elements listed above.

### 2.1 Aluminum Infill Elements

Our analysis is based on the following information:

- Loads: Prescribed by the 2023 Florida Building Code. See Section 1.0 Overview.
- Resistance: Completed in accordance with the AA-ADM-1, Aluminum Design Manual 2020.
- Section properties: Information was provided by Peak™. Calculations were completed in accordance with AA-ADM-1.
- Load configuration: Span and bearing lengths were provided by Peak™.

### 2.2 Glass Infill Elements

Our analysis is based on the following information:

- Loads: Prescribed by the 2023 Florida Building Code. See Section 1.0 Overview.
- Resistance: Completed in accordance with ASTM E1300-16, Standard Practice for Determining Load Resistance of Glass in Buildings.
- Section properties: Determined from drawings provided by Peak™.
- Allowable deflection: The allowable deflection was calculated based on preventing fall-out of the glass from frame.

The infill glazing shall be used only in suitable locations as per Clause 2407.1 of the 2023 Florida Building Code. See excerpt from the 2023 Florida Building Code.

**\*2407.1 Materials.**

*Glass used in a handrail, guardrail, or guard section shall be laminated glass constructed of fully tempered or heat-strengthened glass and shall comply with Category II or CPSC 16 CFR Part 1201 or Class A of ANSI Z97.1. Glazing in railing infill panels shall be of an approved safety glazing material that conforms to provisions of Section 2406.1.1. For all glazing types, the minimum nominal thickness shall be ¼ inch.*

*Exception: Single fully tempered glass complying with Category II of CPSC 16 CFR Part 1201 or Class A of ANSI Z97.1 shall be permitted to be used in handrails and guardrails where there is no walking surface beneath them or the walking surface is permanently protected from the risk of falling glass.*

## 3 Rail Elements

### 3.1 General Rail Elements

The general rail elements include the hand rail, stair hand rail, base rail, and posts. An analysis was completed based on the worst-case configuration for these elements.

- Loads: Prescribed by the 2023 Florida Building Code. See Section 1.0 Overview.
- Resistance: Completed in accordance with the AA-ADM-1, Aluminum Design Manual 2020.
- Section properties: Information was provided by Peak™. Calculations were completed in accordance with AA-ADM-1.
- Fastener resistance: Completed in accordance with AISC 360-16 and AAMA TIR A9-14.
- Load configuration: Span and dimensions were provided by Peak™. Posts were modeled as cantilevers, fixed at the base. The results from our analysis show the maximum span that can be achieved, as calculated from the material and fastener resistances.

## 4 Connectors

### 4.1 General Connectors

The general connectors include the following:

- Universal connector
- Wall mount brackets
- Mid/Stair/End fascia mount bracket
- Corner fascia mount bracket
- Stair hand and base rail brackets

An analysis was completed based on the worst-case configuration for these elements.

- Loads: Prescribed by the 2023 Florida Building Code. See Section 1.0 Overview.
- Resistance: Completed in accordance with the AA-ADM-1, Aluminum Design Manual 2020.
- Section properties: Determined from drawings provided by Peak™. Calculations were completed in accordance with AA-ADM-1.
- Load configuration: Span and dimensions were provided by Peak™.
- Connections to the base building are not included as part of this review, including but not limited to the rail and post connections.

## 5 Results

A full set of calculations and results is presented in RDH compiled engineering review package. The engineering package includes:

- Dimensioned drawings of each component, including extrusion drawings
- Calculation sheets for the structural capacity of components listed in 1.0 Overview.

The above documents contain proprietary information and as such, have not been included in this report.

# 6 Conclusion

The Peak™ Aluminum Railing System meets the requirements within the 2023 Florida Building Code. Limitations of compliance are defined in the assembly drawings presented in Appendix B.

Yours truly,

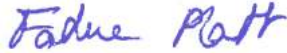

**Fatma Platt** | E.I.T.  
Structural Designer  
fplatt@rdh.com  
**RDH Building Science Inc.**



Reviewed by  
**Barry King**  
Senior Project Manager - Facade  
Structural  
bking@rdh.com  
T 510-788-8915  
**RDH Building Science Inc.**

Encl. Appendix A – List of Components  
Appendix B – Assembly Drawings

## Limits of Commission

RDH prepared this report for the use of Peak™ Products USA Corporation. The material in it reflects RDH’s judgement in light of information available to RDH at the time of preparation, including but not limited to material data sheets, independent testing, and physical mock-ups. Any use that a third party makes of this report, or any reliance or decisions to be based on it, is the responsibility of such third parties. RDH accepts no responsibility for damages, if any, suffered by any third party as a result of decisions made or actions based on this report.

This report was prepared for Peak™ Products USA Corporation. It is not for the use or benefit of, nor may it be relied upon, by any other person or entity, without written permission of RDH Building Science Inc.

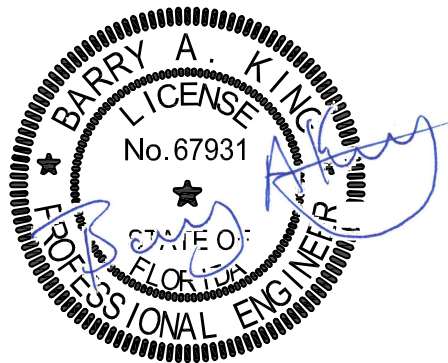

04/28/2024

# **Appendix A**

## **List of Components**

SKU (White)	SKU (Black)	Description	Drawing No.
50000	50001	END POST	post-end R2.5
50010	50011	MID POST	post-mid R2.5
50020	50021	CORNER POST	post-corner R2.6
50050	50051	STAIR POST	post-stair R2.6
50100	50101	4' HAND AND BASE RAIL	hand-rail R2.2, base-rail R2.2, base-rail-support R2.2
50110	50111	6' HAND AND BASE RAIL	hand-rail R2.2, base-rail R2.2, base-rail-support R2.2
50120	50121	8' HAND AND BASE RAIL	hand-rail R2.2, base-rail R2.2, base-rail-support R2.2
50112	50113	STAIR HAND & BASE RAIL	stair-hand-rail R2.2
50200	50201	4' STANDARD PICKETS AND SPACERS	P-S R2.3
50210	50211	6' STANDARD PICKETS AND SPACERS	P-S R2.3
50260	50261	6' STANDARD STAIR PICKETS AND SPACERS	P-S Stair R2.3
50280	50281	SINGLE STAIR PICKET	P-S Stair R2.3
50290	50291	SINGLE NARROW PICKET	P-S R2.3
50300	50301	4' WIDE PICKETS AND SPACERS	P-S Wide R2.2
50310	50311	6' WIDE PICKETS AND SPACERS	P-S Wide R2.2
50360	50361	6' WIDE STAIR PICKETS AND SPACERS	P-S Wide Stair R2.2
50380	50381	SINGLE WIDE STAIR PICKET	P-S Wide Stair R2.2
50390	50391	SINGLE WIDE PICKET	P-S Wide R2.2
50710	50713	6" GLASS PANEL KIT	glass-panel-kit R2.2
50820	50820	GLASS PANEL 18" X 36 5/16"	glass-panel US R2.2
50823	50823	GLASS PANEL 21" X 36 5/16"	glass-panel US R2.2
50830	50830	GLASS PANEL 24" X 36 5/16"	glass-panel US R2.2
50833	50833	GLASS PANEL 27" X 36 5/16"	glass-panel US R2.2
50840	50840	GLASS PANEL 30" X 36 5/16"	glass-panel US R2.2
50843	50843	GLASS PANEL 33" X 36 5/16"	glass-panel US R2.2
50850	50850	GLASS PANEL 36" X 36 5/16"	glass-panel US R2.2
50853	50853	GLASS PANEL 39" X 36 5/16"	glass-panel US R2.2
50860	50860	GLASS PANEL 42" X 36 5/16"	glass-panel US R2.2
50863	50863	GLASS PANEL 45" X 36 5/16"	glass-panel US R2.2
50870	50870	GLASS PANEL 48" X 36 5/16"	glass-panel US R2.2
50873	50873	GLASS PANEL 51" X 36 5/16"	glass-panel US R2.2
50880	50880	GLASS PANEL 54" X 36 5/16"	glass-panel US R2.2
50883	50883	GLASS PANEL 57" X 36 5/16"	glass-panel US R2.2
50888	50888	GLASS PANEL 60" X 36 5/16"	glass-panel US R2.2
50891	50891	GLASS PANEL 63" X 36 5/16"	glass-panel US R2.2
50895	50895	GLASS PANEL 66" X 36 5/16"	glass-panel US R2.2
50900	50901	UNIVERSAL CONNECTOR	ubracekt-handrail R2.2, ubracekt-baserail R2.2, ubracekt-wall R2.2
50902	50903	STAIR HAND AND BASE RAIL BRACKET KIT	ubracekt-stair-hand-rail R2.2, ubracekt-baserail R2.2, ubracekt-wall R2.2
50910	50911	BOTTOM RAIL SUPPORT	base-rail-support R2.2
50920	50921	WALL MOUNT BRACKETS	wall-bracket-hand-rail R2.2, wall-bracket-base-rail R2.2
50940	50940	6' GLASS GASKET	glass-gasket-kit R2.2
50960	50961	CORNER FASCIA MOUNT BRACKET	fascia-mount-corner R2.2
50970	50971	MID/END/STAIR FASCIA MOUNT BRACKET	fascia-mount-mid R2.4

# **Appendix B**

## **Assembly Drawings**

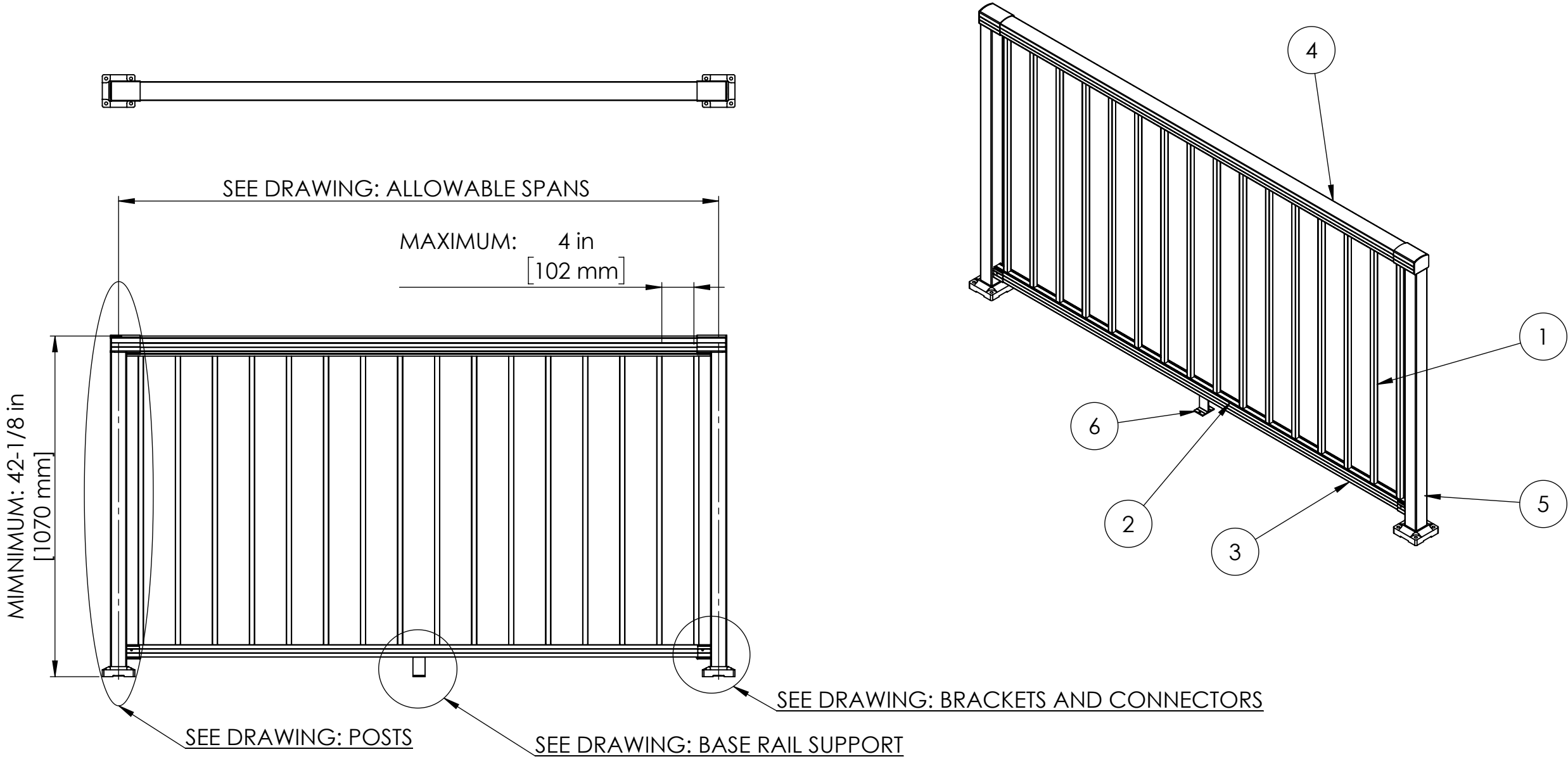

ITEM NO.	DESCRIPTION	SKU
1	STANDARD PICKET	50200, 50201, 50210, 50211, 50290, 50291
2	SPACER	50200, 50201, 50210, 50211, 50290, 50291
3	BASE RAIL	50100, 50101, 50110, 50111, 50120, 50121
4	HAND RAIL	50100, 50101, 50110, 50111, 50120, 50121
5	POST	50000, 50001, 50010, 50011, 50020, 50021, 50050, 50051
6	BASE RAIL SUPPORT	50100, 50101, 50110, 50111, 50120, 50121



TITLE  
Aluminum Railing - Standard Picket Assembly

PART FILE  
Report assembly - pickets

DWG REV C

DIMENSIONS ARE IN MM UNLESS NOTED  
DO NOT SCALE DRAWING

**PROPRIETARY AND CONFIDENTIAL**  
THE INFORMATION CONTAINED IN THIS DRAWING IS THE SOLE PROPERTY OF THE PEAK GROUP OF COMPANIES. ANY REPRODUCTION IN PART OR AS A WHOLE WITHOUT THE WRITTEN PERMISSION OF THE PEAK GROUP OF COMPANIES IS PROHIBITED.

SIZE	DWG. NO.
<b>B</b>	Report assembly PAR US-Com Pickets

SCALE: 1:15	<small>SHT REV</small> 2015-03-03-A
-------------	----------------------------------------

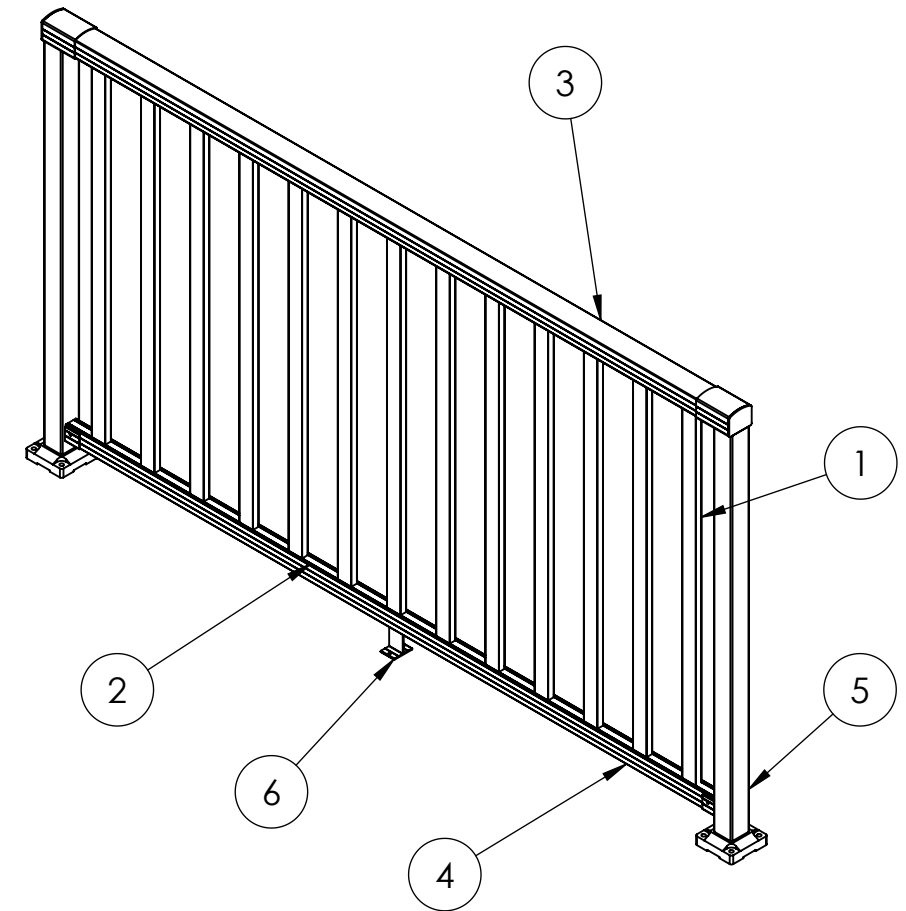
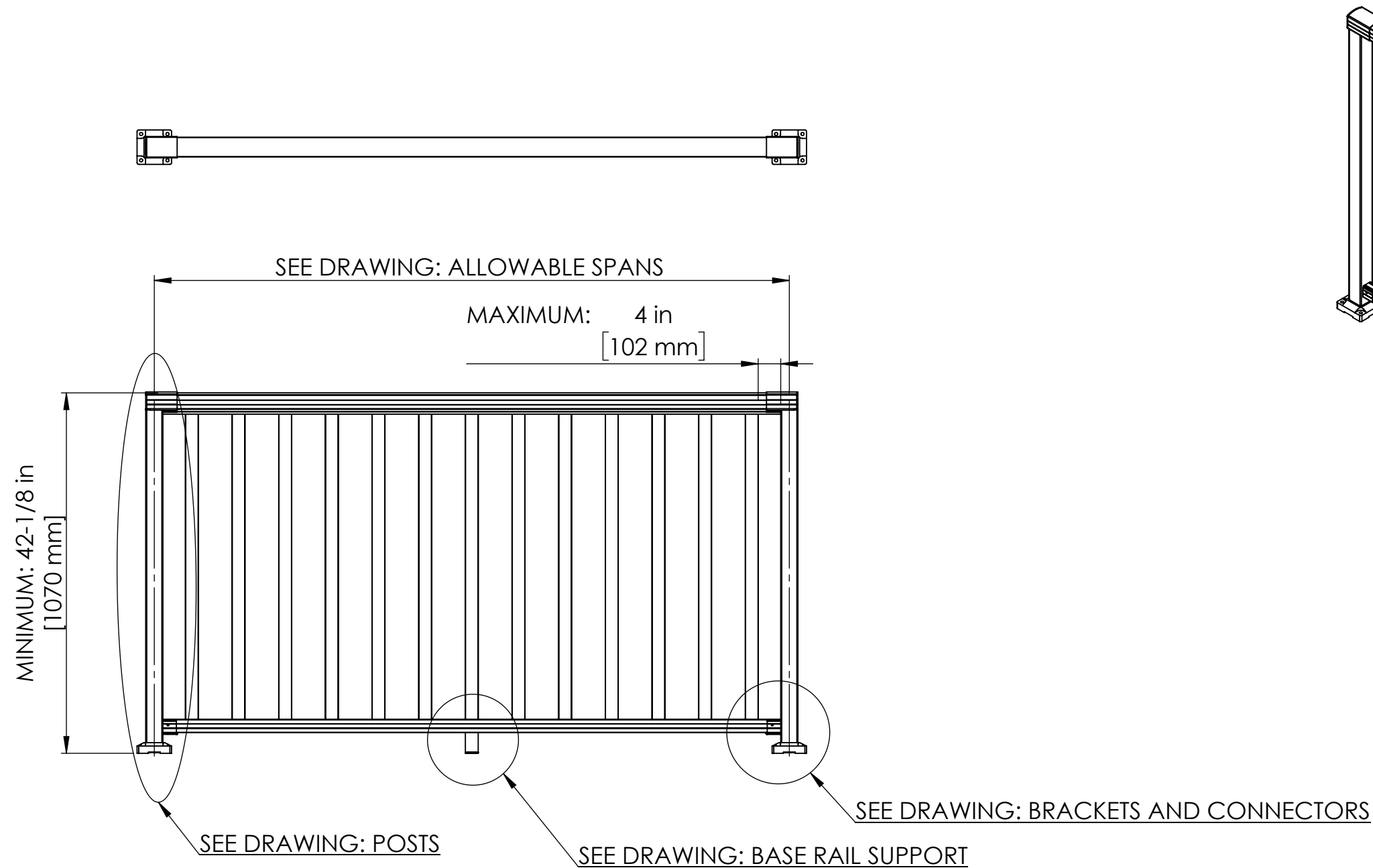

ITEM NO.	DESCRIPTION	SKU
1	WIDE PICKET	50300, 50301, 50310, 50311, 50390, 50391
2	SPACER	50300, 50301, 50310, 50311, 50390, 50391
3	HAND RAIL	50100, 50101, 50110, 50111, 50120, 50121
4	BASE RAIL	50100, 50101, 50110, 50111, 50120, 50121
5	POST	50000, 50001, 50010, 50011, 50020, 50021, 50050, 50051
6	BASE RAIL SUPPORT	50100, 50101, 50110, 50111, 50120, 50121

**PEAK**

TITLE  
 Aluminum Railing - Wide Pickets Assembly

PART FILE  
 Report assembly - wide pickets

DWG REV B

DIMENSIONS ARE IN MM UNLESS NOTED  
 DO NOT SCALE DRAWING

**PROPRIETARY AND CONFIDENTIAL**  
THE INFORMATION CONTAINED IN THIS DRAWING IS THE SOLE PROPERTY OF THE PEAK GROUP OF COMPANIES. ANY REPRODUCTION IN PART OR AS A WHOLE WITHOUT THE WRITTEN PERMISSION OF THE PEAK GROUP OF COMPANIES IS PROHIBITED.

SIZE	DWG. NO.
<b>B</b>	Report assembly PAR US-Com Wide Pickets
SCALE: 1:15	SHT REV 2015-03-03-A

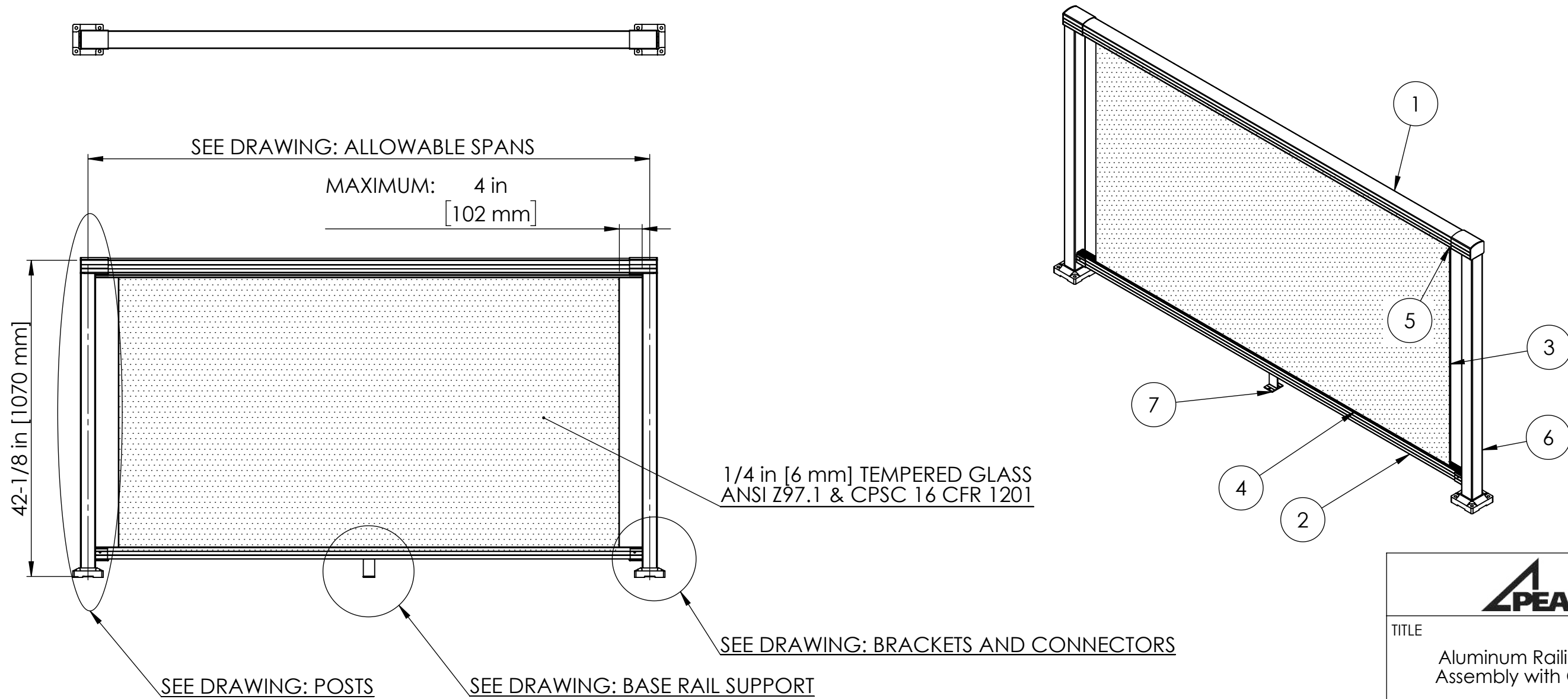

ITEM NO.	DESCRIPTION	SKU
1	HAND RAIL	50100, 50101, 50110, 50111, 50120, 50121
2	BASE RAIL	50100, 50101, 50110, 50111, 50120, 50121
3	GLASS PANEL	50820, 50823, 50830, 50833, 50840, 50843, 50850, 50853, 50860, 50863, 50870, 50873, 50880, 50883, 50888, 50891, 50895
4	LOWER GLASS GASKET	50940
5	UPPER GLASS GASKET	50940
6	POST	50000, 50001, 50010, 50011, 50020, 50021, 50050, 50051
7	BASE RAIL SUPPORT	50100, 50101, 50110, 50111, 50120, 50121

**PEAK**

TITLE  
Aluminum Railing - Railing Assembly with Glass Panel

PART FILE  
Report assembly - glass panel

DWG REV C

DIMENSIONS ARE IN MM UNLESS NOTED  
DO NOT SCALE DRAWING

**PROPRIETARY AND CONFIDENTIAL**  
THE INFORMATION CONTAINED IN THIS DRAWING IS THE SOLE PROPERTY OF THE PEAK GROUP OF COMPANIES. ANY REPRODUCTION IN PART OR AS A WHOLE WITHOUT THE WRITTEN PERMISSION OF THE PEAK GROUP OF COMPANIES IS PROHIBITED.

SIZE	DWG. NO.
<b>B</b>	Report assembly PAR US-Com Glass Panel

SCALE: 1:15 SHT REV 2015-03-03-A

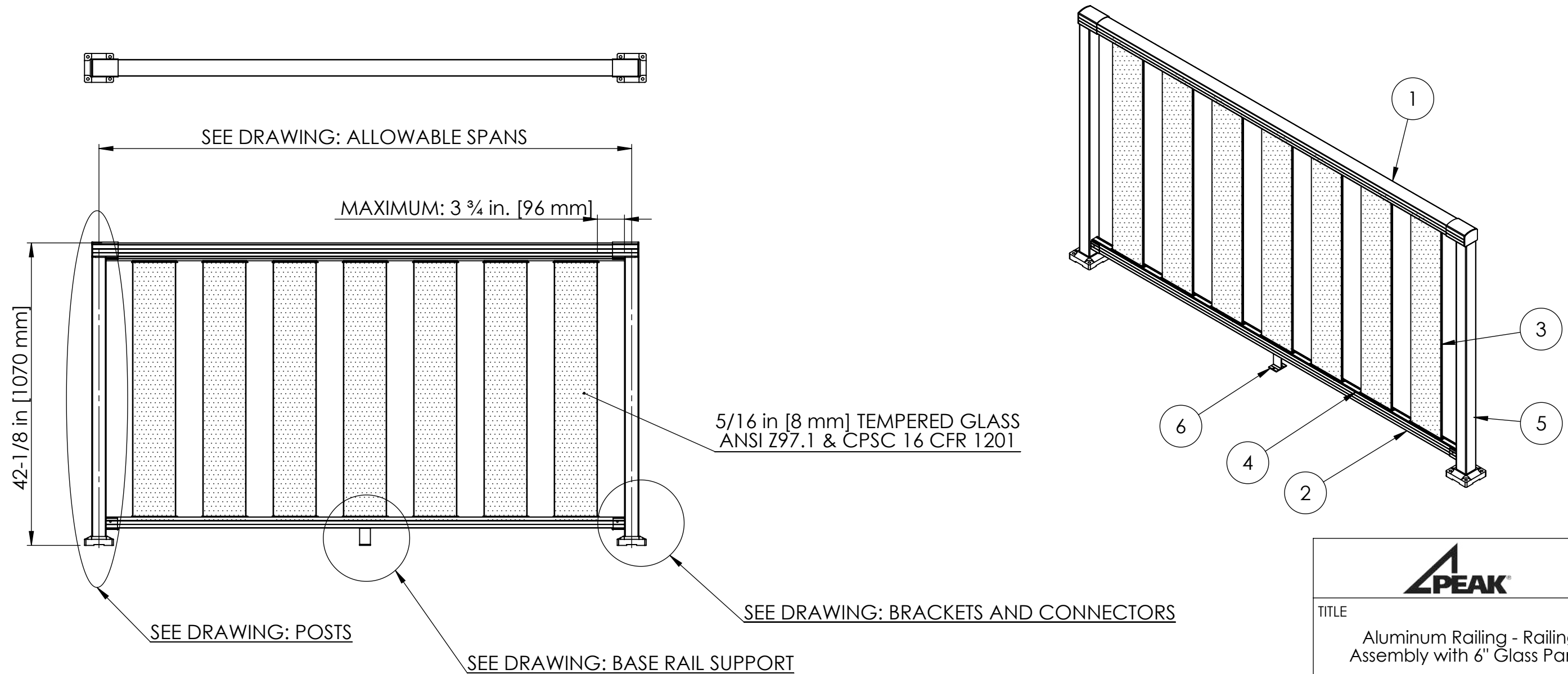

ITEM NO.	DESCRIPTION	SKU
1	HAND RAIL	50100, 50101, 50110, 50111, 50120, 50121
2	BASE RAIL	50100, 50101, 50110, 50111, 50120, 50121
3	6" GLASS PANEL & GASKET	50710, 50713
4	SPACER	50710, 50713
5	POST	50000, 50001, 50010, 50011, 50020, 50021, 50050, 50051
6	BASE RAIL SUPPORT	50100, 50101, 50110, 50111, 50120, 50121

**PEAK**

TITLE  
Aluminum Railing - Railing Assembly with 6" Glass Panel

PART FILE  
Report assembly - glass pickets

DWG REV C

DIMENSIONS ARE IN MM UNLESS NOTED  
DO NOT SCALE DRAWING

**PROPRIETARY AND CONFIDENTIAL**  
THE INFORMATION CONTAINED IN THIS DRAWING IS THE SOLE PROPERTY OF THE PEAK GROUP OF COMPANIES. ANY REPRODUCTION IN PART OR AS A WHOLE WITHOUT THE WRITTEN PERMISSION OF THE PEAK GROUP OF COMPANIES IS PROHIBITED.

SIZE <b>B</b>	DWG. NO. Report assembly PAR US-Com 6in Glass Panels
SCALE: 1:15	SHT REV 2015-03-03-A

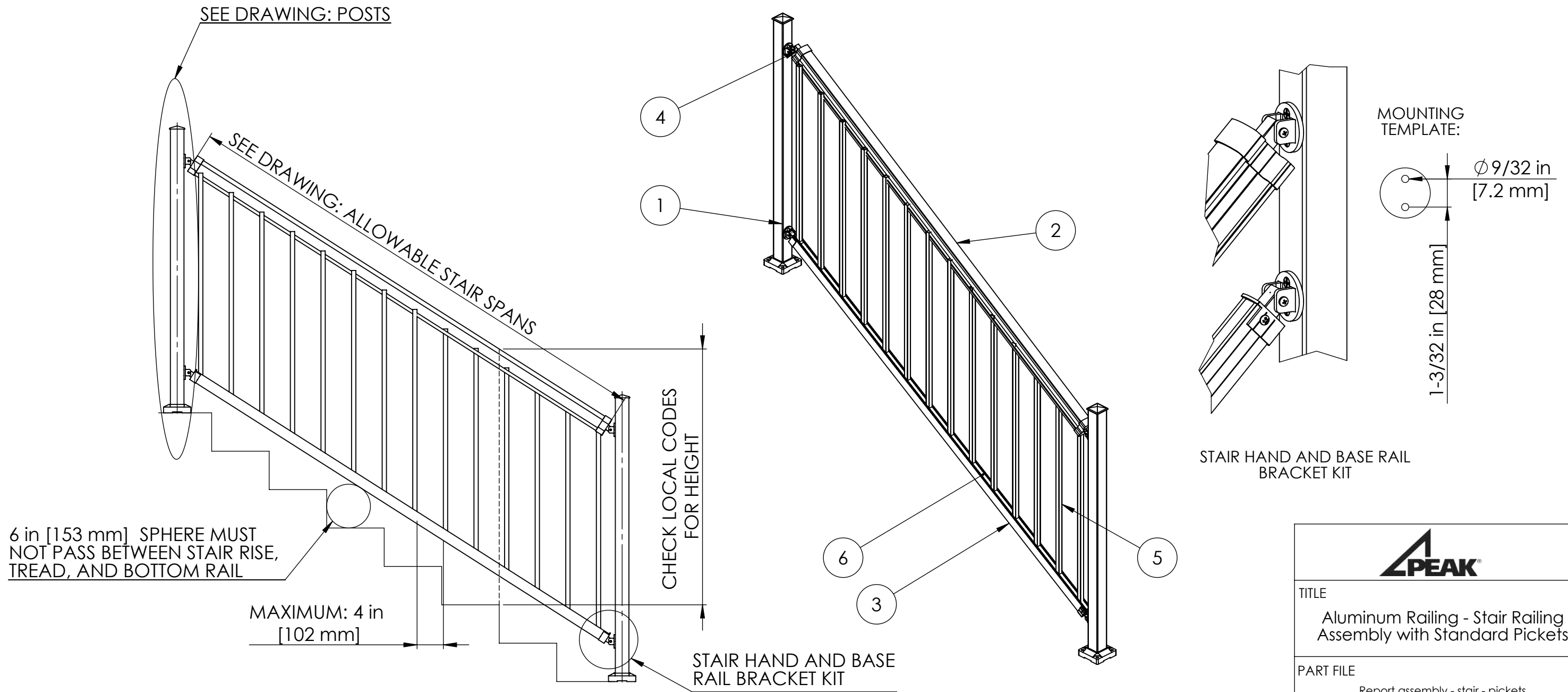

ITEM NO.	DESCRIPTION	SKU
1	POST	50000, 50001, 50050, 50051
2	STAIR HAND RAIL	50112, 50113
3	BASE RAIL	50112, 50113
4	STAIR HANDRAIL BRACKET	50902, 50903
5	STANDARD STAIR PICKET	50260, 50261, 50280, 50281
6	STAIR SPACER	50260, 50261, 50280, 50281

**PEAK**

TITLE  
 Aluminum Railing - Stair Railing Assembly with Standard Pickets

PART FILE  
 Report assembly - stair - pickets

DWG REV C

DIMENSIONS ARE IN MM UNLESS NOTED  
 DO NOT SCALE DRAWING

**PROPRIETARY AND CONFIDENTIAL**  
THE INFORMATION CONTAINED IN THIS DRAWING IS THE SOLE PROPERTY OF THE PEAK GROUP OF COMPANIES. ANY REPRODUCTION IN PART OR AS A WHOLE WITHOUT THE WRITTEN PERMISSION OF THE PEAK GROUP OF COMPANIES IS PROHIBITED.

SIZE	DWG. NO.
<b>B</b>	Report assembly PAR US-Com Stair Pickets

SCALE: 1:15 SHT REV 2015-03-03-A

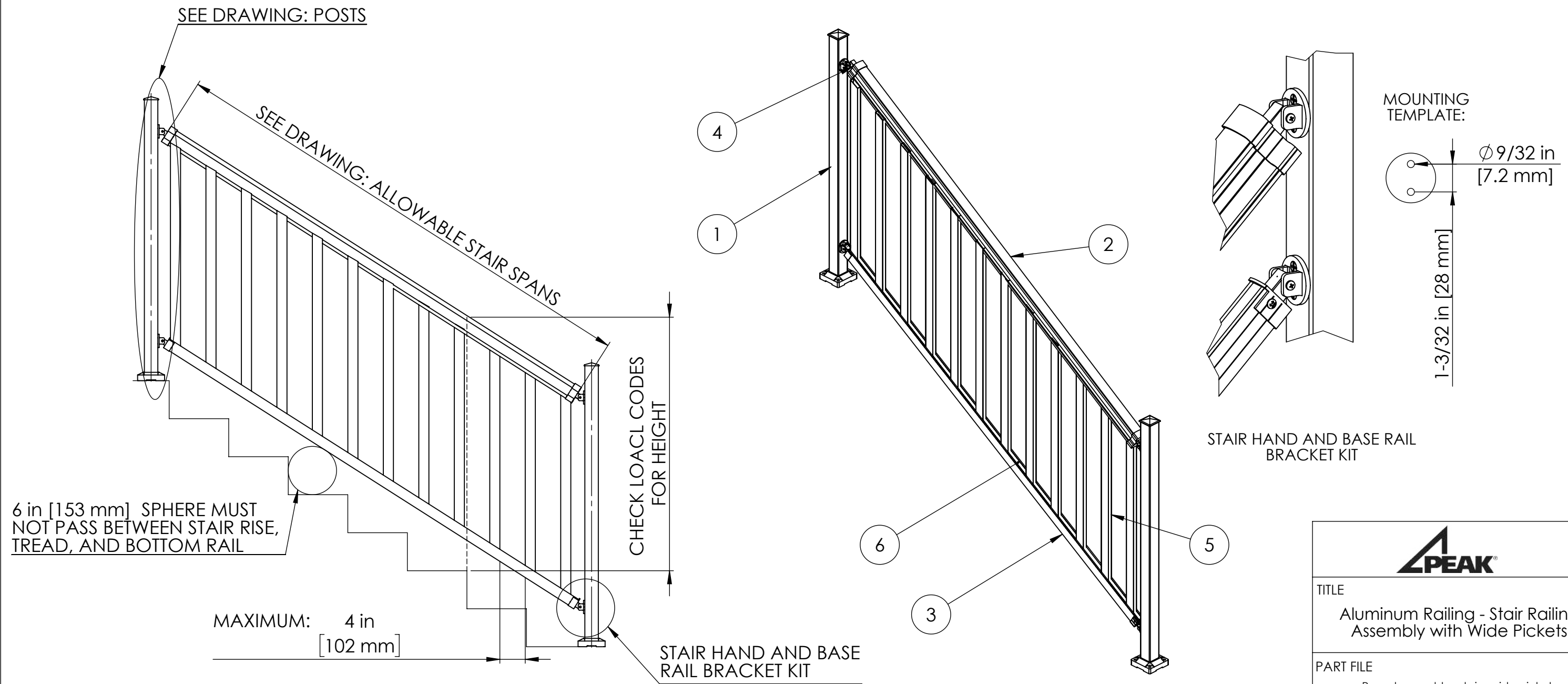

ITEM NO.	DESCRIPTION	SKU
1	POST	50000, 50001, 50050, 50051
2	STAIR HAND RAIL	50112, 50113
3	BASE RAIL	50112, 50113
4	STAIR HANDRAIL BRACKET	50902, 50903
5	WIDE STAIR PICKET	50360, 50361, 50380, 50381
6	STAIR SPACER	50360, 50361, 50380, 50381



TITLE  
**Aluminum Railing - Stair Railing Assembly with Wide Pickets**

PART FILE  
 Report assembly - stair - wide pickets

DWG REV    C

DIMENSIONS ARE IN MM UNLESS NOTED  
 DO NOT SCALE DRAWING

**PROPRIETARY AND CONFIDENTIAL**  
THE INFORMATION CONTAINED IN THIS DRAWING IS THE SOLE PROPERTY OF THE PEAK GROUP OF COMPANIES. ANY REPRODUCTION IN PART OR AS A WHOLE WITHOUT THE WRITTEN PERMISSION OF THE PEAK GROUP OF COMPANIES IS PROHIBITED.

SIZE	DWG. NO.
<b>B</b>	Report assembly PAR US-Com Stair Wide Pickets

SCALE: 1:15    SHT REV 2015-03-03-A

**SINGLE RAILING PICKET SECTION**

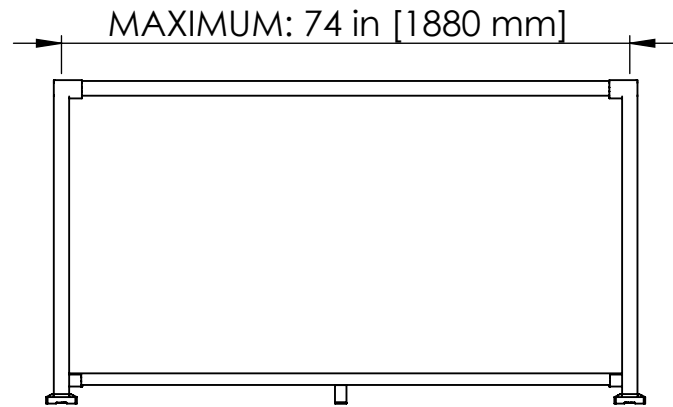

**WALL MOUNT PICKET SECTION**

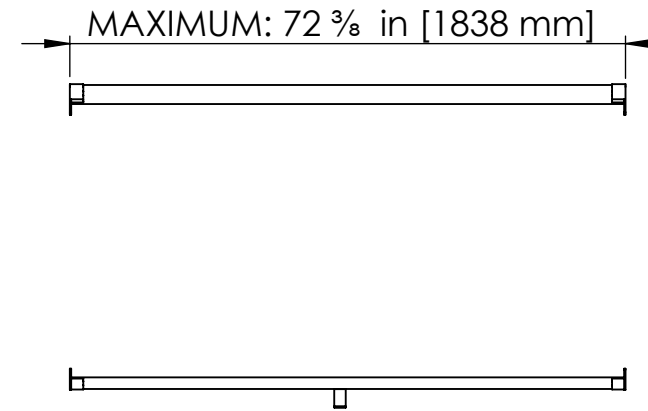

**MULTIPLE RAILING PICKET SECTIONS**

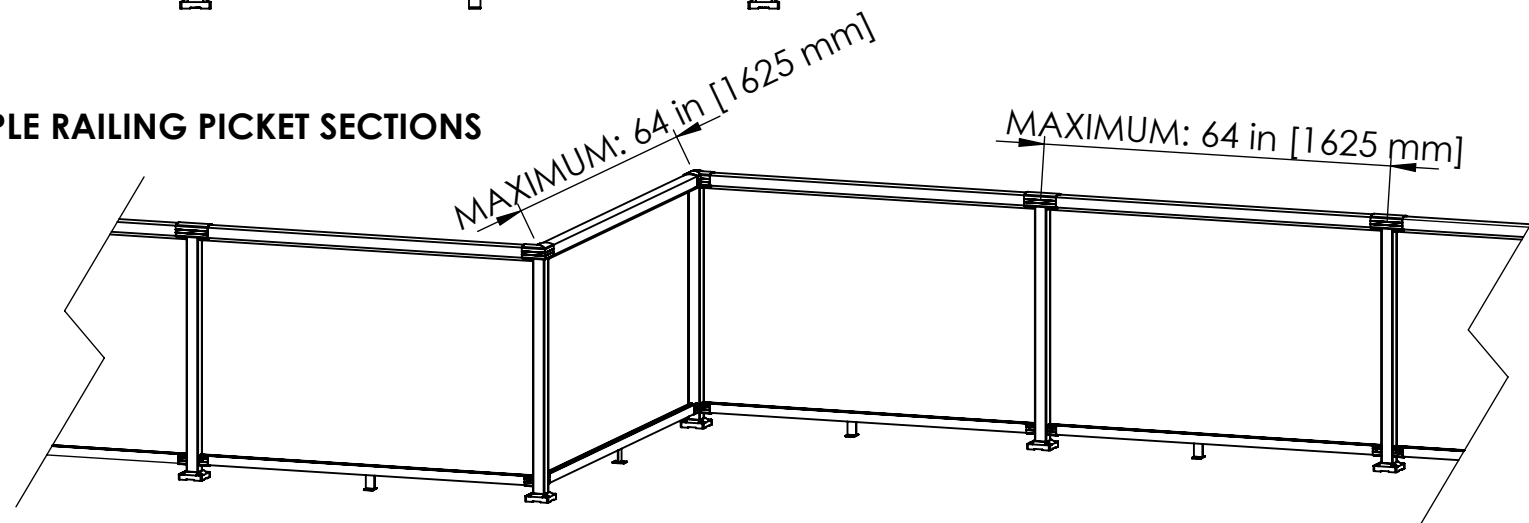

**MAXIMUM ALLOWABLE SPANS FOR 18 in. - 66 in. GLASS PANELS (in.)**

Configuration	Design Wind Pressure (psf)												
	12	16	20	24	28	32	36	40	44	48	52	56	60
Single Railing Section	74	74	74	69 5/8	65 1/4	61 3/4	58 3/4	56 1/4	54	52 1/8	50 3/8	48 7/8	47 1/2
Wall Mount Section	72 3/8	72 3/8	72 3/8	67 5/8	63 3/8	59 3/4	56 7/8	54 1/4	52	50 1/8	48 1/2	46 7/8	45 1/2
Multiple Railing Section	64	64	64	64	64	61 3/4	58 3/4	56 1/4	53 1/2	50	46 7/8	43 1/2	40 1/2

**MAXIMUM ALLOWABLE SPANS FOR 6 in. GLASS PANELS (in.)**

Configuration	Design Wind Pressure (psf)												
	12	16	20	24	28	32	36	40	44	48	52	56	60
Single Railing Section	74	74	74	74	74	74	72	68 7/8	66 1/4	63 7/8	61 3/4	59 7/8	58 1/8
Wall Mount Section	72 3/8	72 3/8	72 3/8	72 3/8	72 3/8	72 3/8	70	67	64 1/4	61 7/8	59 3/4	57 7/8	56 1/8
Multiple Railing Section	64	64	64	64	64	64	64	64	64	61 7/8	59 3/4	57 7/8	56 1/8



TITLE  
Aluminum Railing - Allowable Spans

PART FILE  
Report assembly P4 Span 74in

DWG REV B

DIMENSIONS ARE IN MM UNLESS NOTED  
DO NOT SCALE DRAWING

**PROPRIETARY AND CONFIDENTIAL**  
THE INFORMATION CONTAINED IN THIS DRAWING IS THE SOLE PROPERTY OF THE PEAK GROUP OF COMPANIES. ANY REPRODUCTION IN PART OR AS A WHOLE WITHOUT THE WRITTEN PERMISSION OF THE PEAK GROUP OF COMPANIES IS PROHIBITED.

SIZE B DWG. NO.  
Report assembly PAR US-Com Span - Wind US

SCALE: 1:20 SH1 REV 2015-03-03-A

**L-SHAPED CORNER SECTION: END POST**

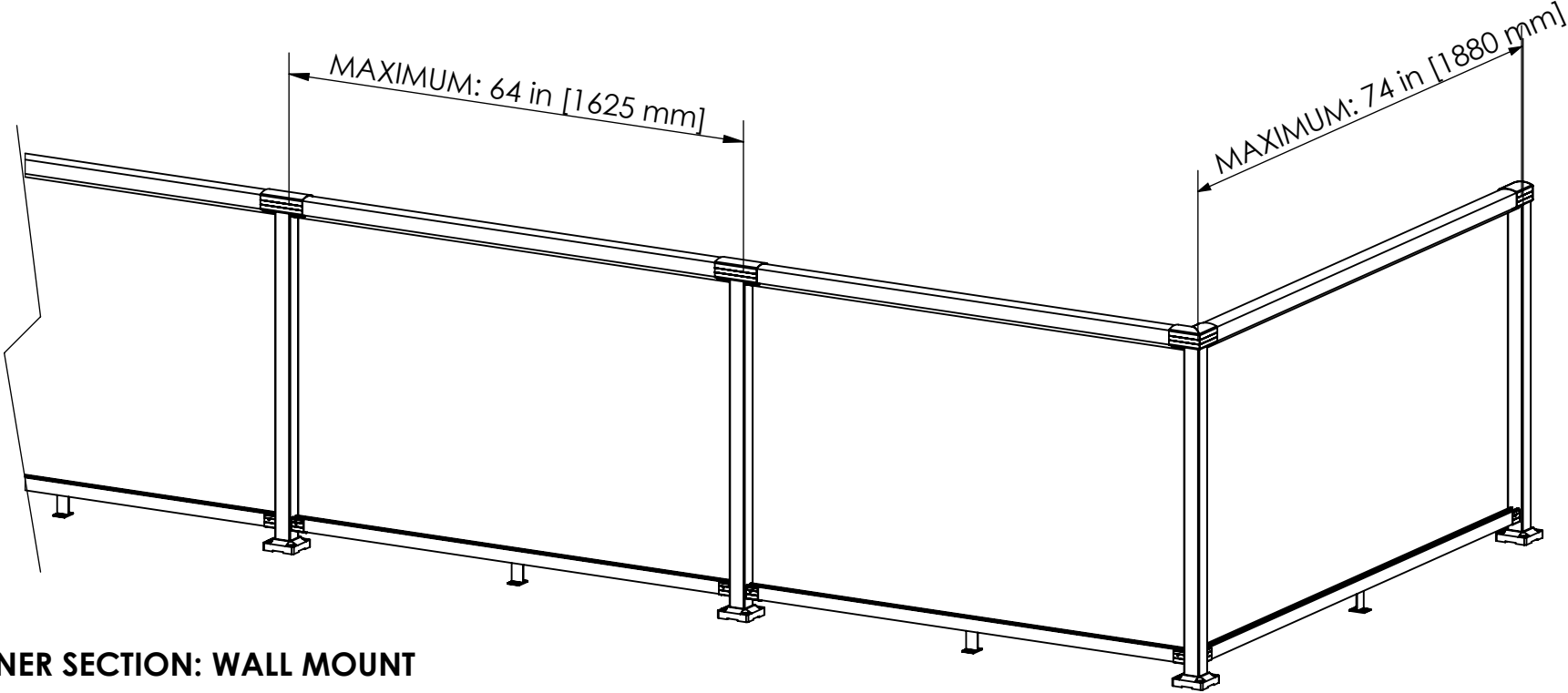

NOTE: Refer to drawing "Aluminum Railing - Allowable Spans" for multiple railing section allowable spans

**L-SHAPED CORNER SECTION: WALL MOUNT**

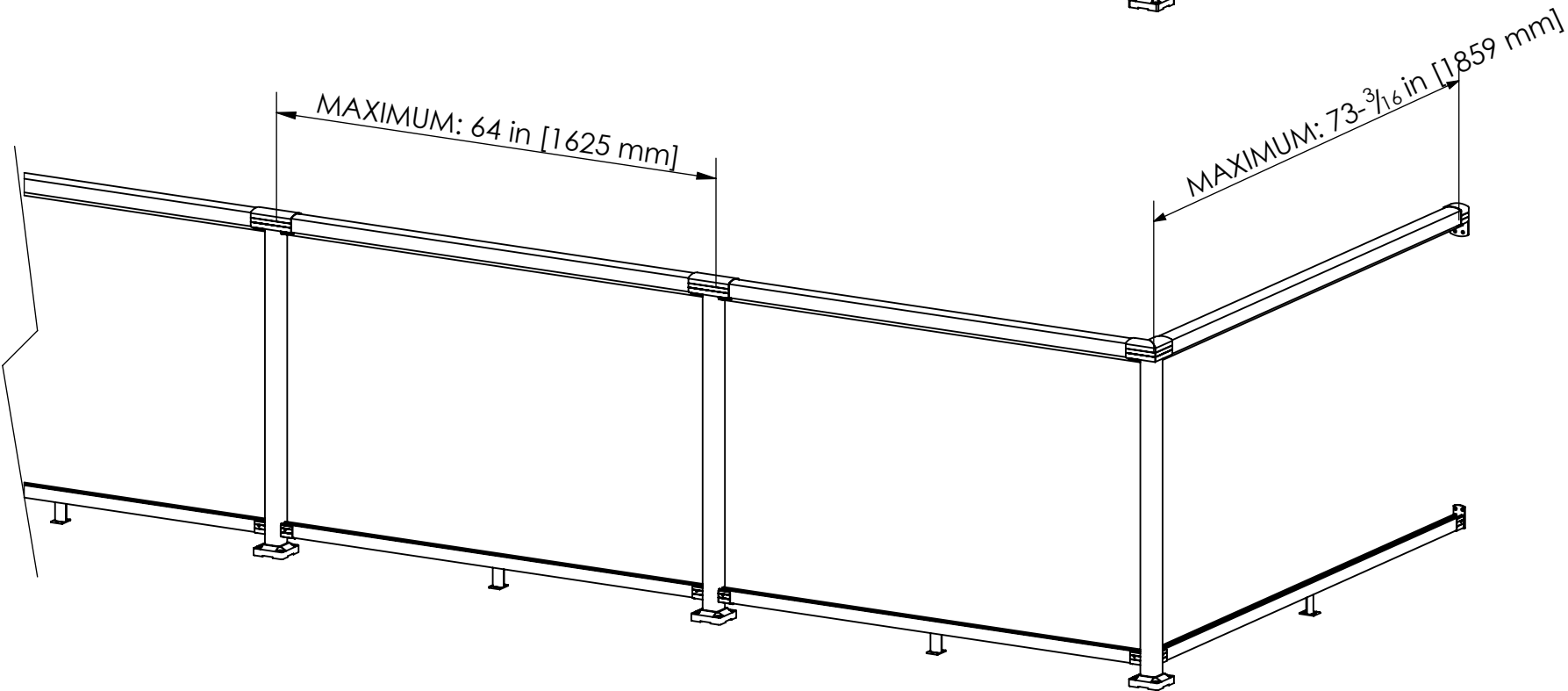

TITLE Aluminum Railing Allowable Spans - Multiple Spans with Single Return	
PART FILE US - Return	
DWG REV      B	
DIMENSIONS ARE IN MM UNLESS NOTED DO NOT SCALE DRAWING	
<b>PROPRIETARY AND CONFIDENTIAL</b> THE INFORMATION CONTAINED IN THIS DRAWING IS THE SOLE PROPERTY OF THE PEAK GROUP OF COMPANIES. ANY REPRODUCTION IN PART OR AS A WHOLE WITHOUT THE WRITTEN PERMISSION OF THE PEAK GROUP OF COMPANIES IS PROHIBITED.	
SIZE <b>B</b>	DWG. NO. Report assembly PAR US-Com Span - L-Return
SCALE: 1:20	SHT REV 2015-03-03-A

**MULTIPLE STAIR RAILING SECTIONS**

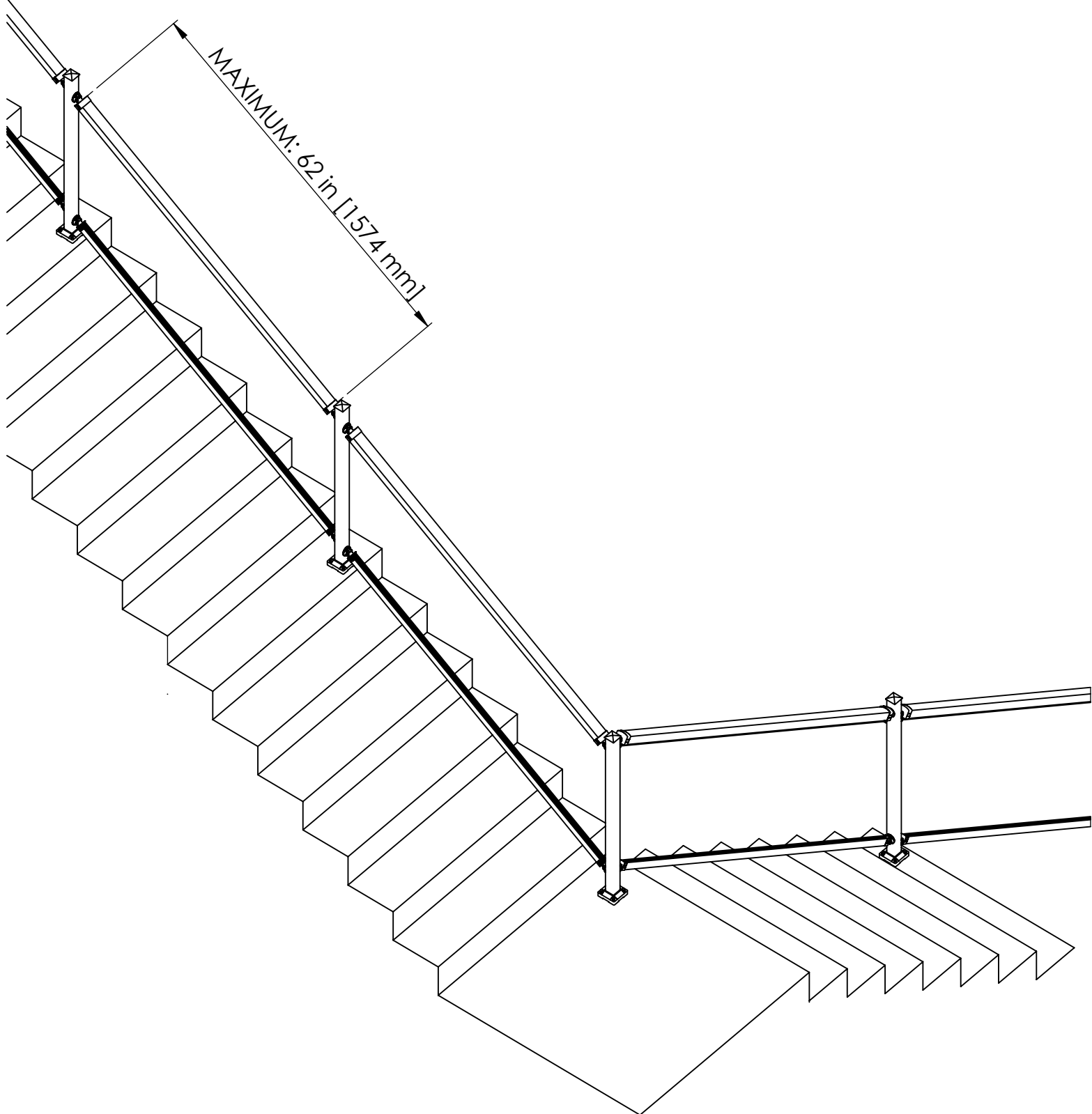

**SINGLE RAILING SECTION**

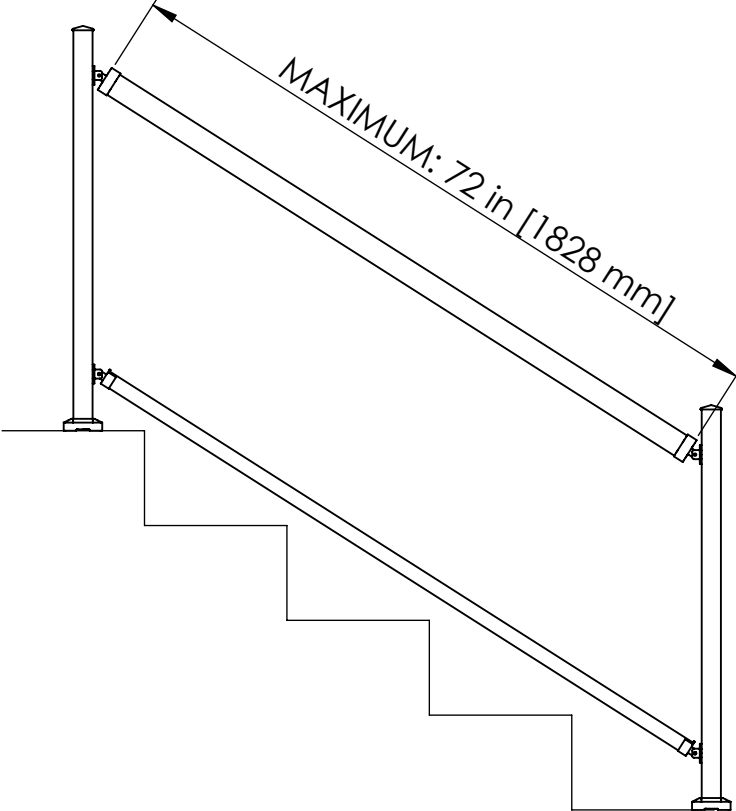

TITLE  
 Aluminum Railing - Allowable  
 Stair Spans

PART FILE  
 Report assembly - stair span single

DWG REV B

DIMENSIONS ARE IN MM UNLESS NOTED  
 DO NOT SCALE DRAWING

**PROPRIETARY AND CONFIDENTIAL**  
 THE INFORMATION CONTAINED IN THIS DRAWING IS THE SOLE  
 PROPERTY OF THE PEAK GROUP OF COMPANIES. ANY REPRODUCTION  
 IN PART OR AS A WHOLE WITHOUT THE WRITTEN PERMISSION OF THE  
 PEAK GROUP OF COMPANIES IS PROHIBITED.

SIZE	DWG. NO.
<b>B</b>	Report assembly PAR US-Com Stair Span

SCALE: 1:20	SHT REV 2015-03-03-A
-------------	-------------------------

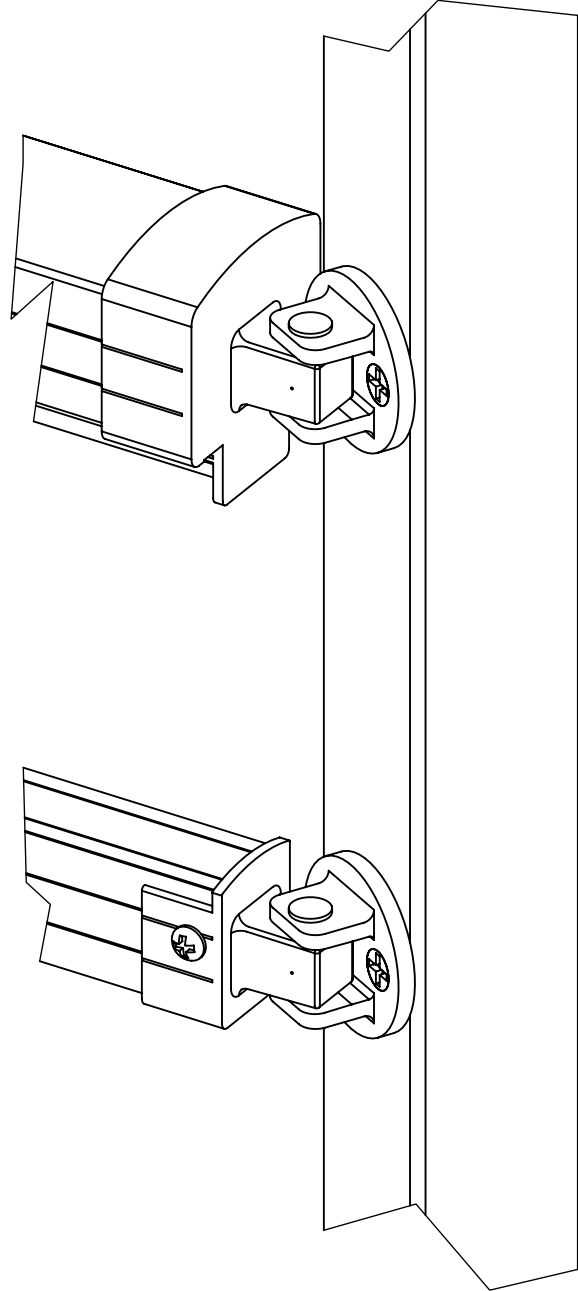

UNIVERSAL CONNECTOR -  
HORIZONTAL INSTALLATION  
SKU: 50900, 50901

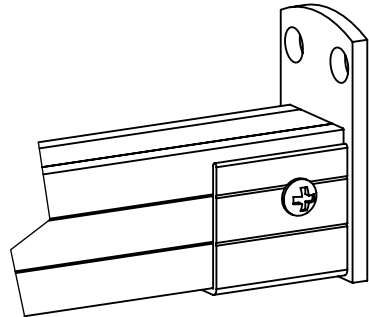
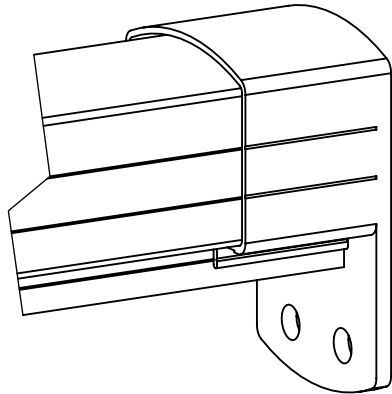
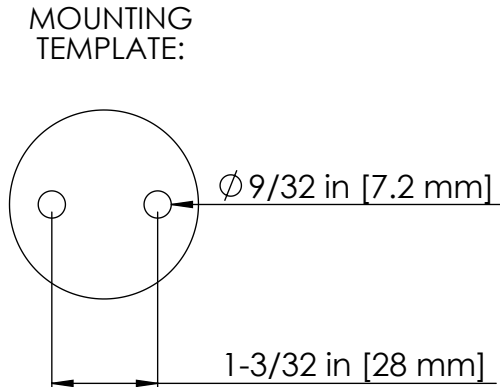

WALL MOUNT BRACKETS  
SKU: 50920, 50921

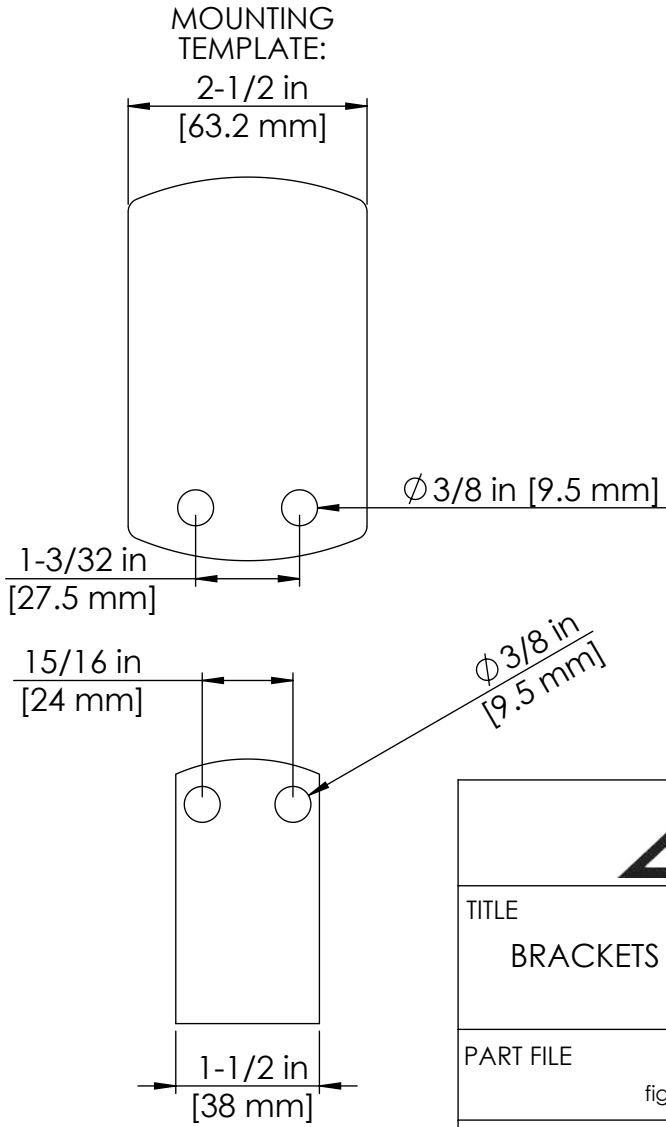

TITLE BRACKETS AND CONNECTORS	
PART FILE fig-ubricks-horiz	
DWG REV C	
DIMENSIONS ARE IN MM UNLESS NOTED DO NOT SCALE DRAWING	
PROPRIETARY AND CONFIDENTIAL THE INFORMATION CONTAINED IN THIS DRAWING IS THE SOLE PROPERTY OF THE PEAK GROUP OF COMPANIES. ANY REPRODUCTION IN PART OR AS A WHOLE WITHOUT THE WRITTEN PERMISSION OF THE PEAK GROUP OF COMPANIES IS PROHIBITED.	
SIZE <b>B</b>	DWG. NO. Report-brackets PAR US-Com
SCALE: 1:2	SHT REV 2015-03-03-A

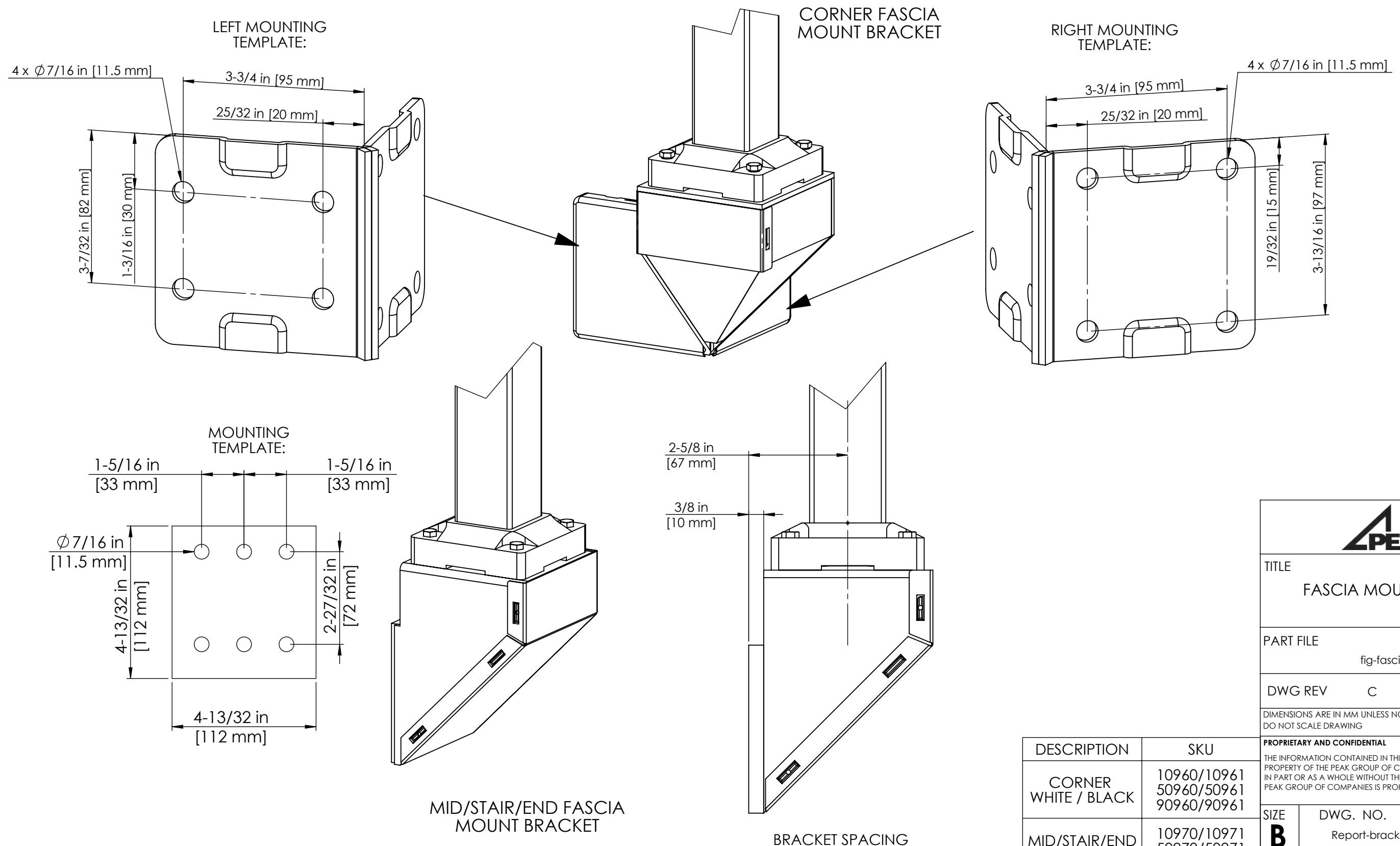

TITLE FASCIA MOUNT BRACKETS	
PART FILE fig-fascia-corner	
DWG REV C	
DIMENSIONS ARE IN MM UNLESS NOTED DO NOT SCALE DRAWING	
<b>PROPRIETARY AND CONFIDENTIAL</b> THE INFORMATION CONTAINED IN THIS DRAWING IS THE SOLE PROPERTY OF THE PEAK GROUP OF COMPANIES. ANY REPRODUCTION IN PART OR AS A WHOLE WITHOUT THE WRITTEN PERMISSION OF THE PEAK GROUP OF COMPANIES IS PROHIBITED.	
DESCRIPTION	SKU
CORNER WHITE / BLACK	10960/10961 50960/50961 90960/90961
MID/STAIR/END WHITE/BLACK	10970/10971 50970/50971 90970/90971
SIZE <b>B</b>	DWG. NO. Report-brackets PAR US-Com
SCALE: 1:3	SHT REV 2015-03-03-A

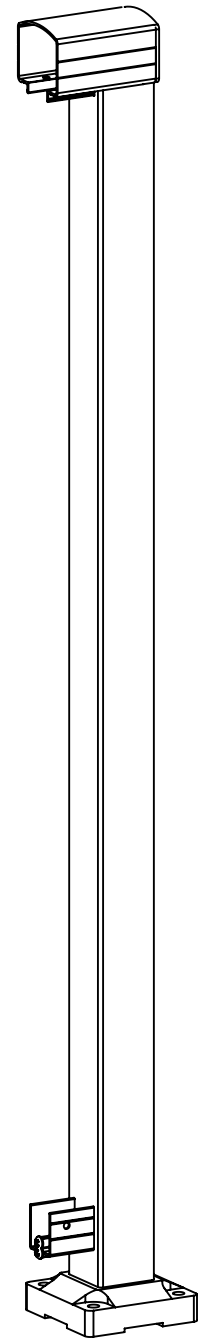

END POST

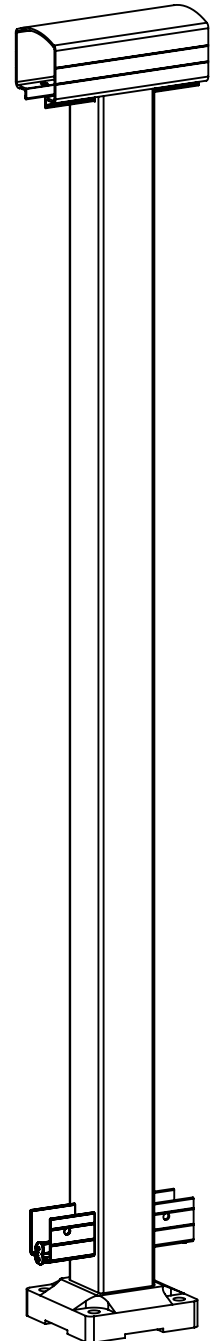

MID POST

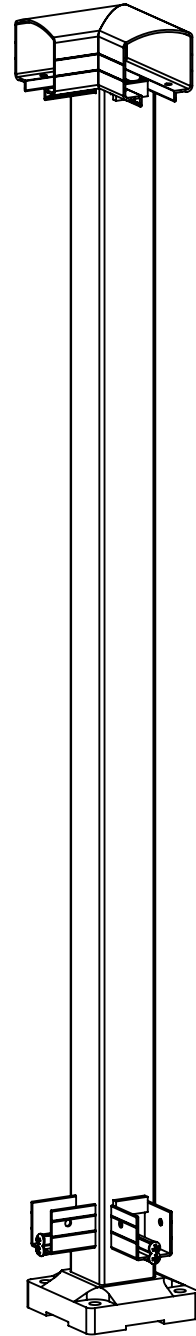

CORNER POST

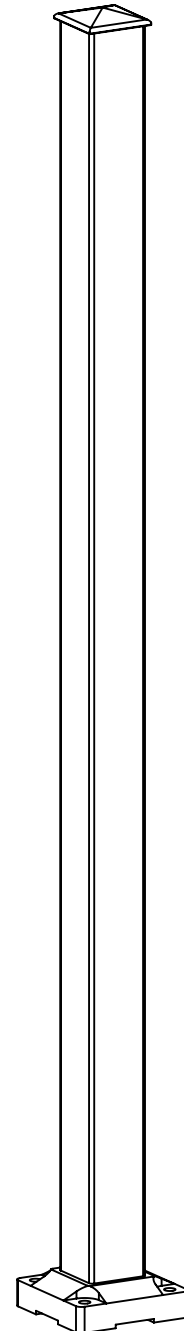

STAIR POST

MOUNTING  
TEMPLATE:

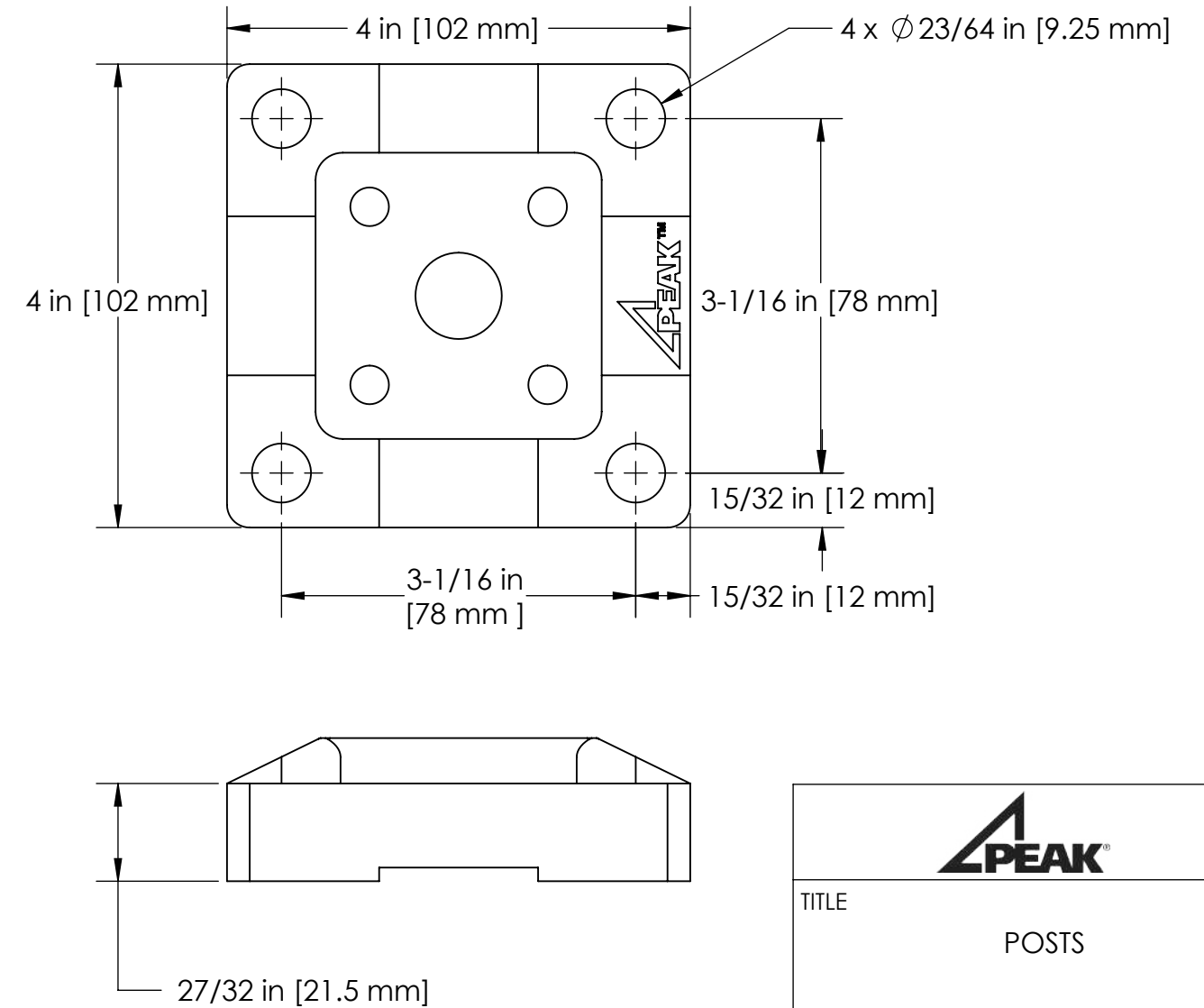

TITLE		POSTS	
PART FILE		fig-post-corner PAB	
DWG REV		C	
DIMENSIONS ARE IN MM UNLESS NOTED DO NOT SCALE DRAWING			
PROPRIETARY AND CONFIDENTIAL THE INFORMATION CONTAINED IN THIS DRAWING IS THE SOLE PROPERTY OF THE PEAK GROUP OF COMPANIES. ANY REPRODUCTION IN PART OR AS A WHOLE WITHOUT THE WRITTEN PERMISSION OF THE PEAK GROUP OF COMPANIES IS PROHIBITED.			
SIZE	DWG. NO.		
<b>B</b>	Report-posts PAR		
SCALE: 1:8	SHT REV	2015-03-03-A	

DESCRIPTION	SKU
END POST	50000, 50001
MID POST	50010, 50011
CORNER POST	50020, 50021
STAIR POST	50050, 50051

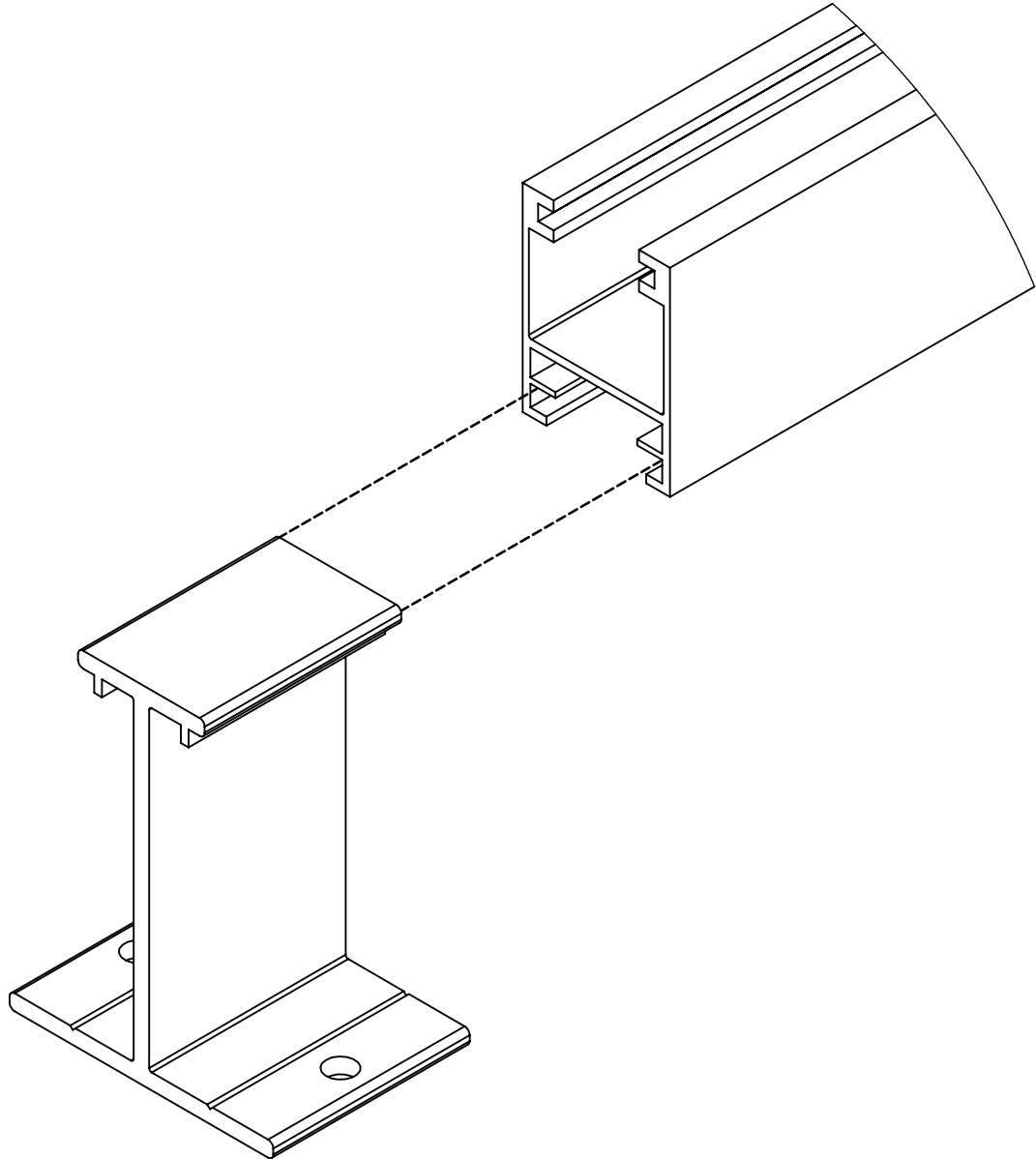

MOUNTING TEMPLATE:

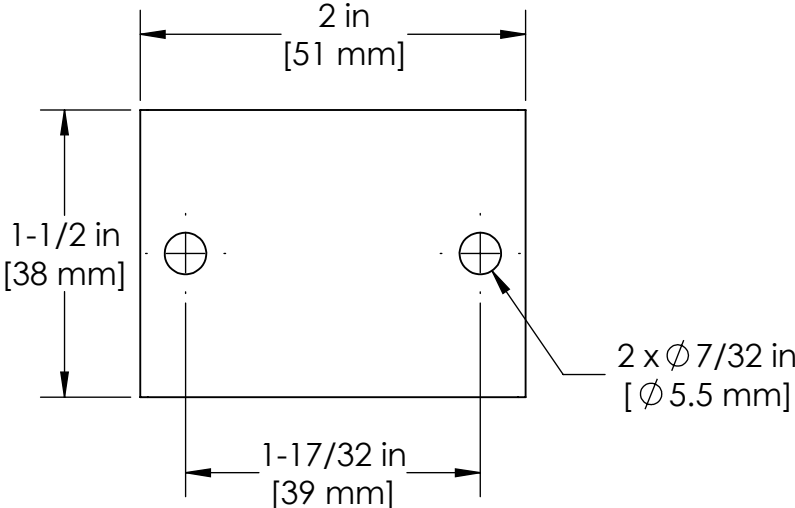

TITLE BASE RAIL SUPPORT	
PART FILE Report assembly - base rail support	
DWG REV     A	
DIMENSIONS ARE IN MM UNLESS NOTED DO NOT SCALE DRAWING	
<b>PROPRIETARY AND CONFIDENTIAL</b> THE INFORMATION CONTAINED IN THIS DRAWING IS THE SOLE PROPERTY OF THE PEAK GROUP OF COMPANIES. ANY REPRODUCTION IN PART OR AS A WHOLE WITHOUT THE WRITTEN PERMISSION OF THE PEAK GROUP OF COMPANIES IS PROHIBITED.	
SIZE <b>B</b>	DWG. NO. BASE RAIL SUPPORT
SCALE: 1:1	SHT REV 2015-03-03-A